



Fruitland Liquid Ring Vacuum Pump

WR 2500 & WR 3100

Flanges 180 turnable,
connection flange horizontal
or vertical

mechanical seal for
shaft seal

Shaft diameter 48 mm

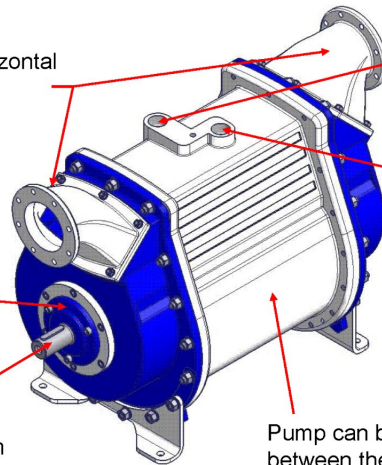

Connection for
air injection

Connection for
water inlet

Pump can be turned 22,5°
between the mounting feet

- Easy to Install
- Strong Durable Components
- Low Power Requirement
- Large Volume Flow Range
- Low Weight Aluminum Design

		VacuStar WR 2500	VacuStar WR 3100
Max. Volume Flow	m ³ /h/ cfm	2500/1470	3100/1825
Max. Operating Pressure	bar g/ psig	1.5/21.3	1.5/21.3
Max. Operating Vacuum*	mbar/ HG"	130/26	130/26
Speed Range	rpm	800-1600	800-1600
Max. Power Requirement at 0.5 bar g/7.25	kW/ hp	77.0/105	94.0/128
Sound Pressure Level in 7m distance at 400mbar/18 HG"	dB(A)	70	72
Weight	Kg/lb	175/385	192/422

*Depending on cooling water temperature

2901 North Freeway ♦ Fort Worth, Texas 76106

817-624-3181 ♦ 800-709-3184 ♦ WWW.FORTWORTHTRUCK.COM

