

F E A T U R E S

Hydra - Kool is an all aluminum, lightweight, compact Cooler - Filter - Reservoir system. The ideal solution for mobile hydraulic applications where weight reduction is vital to reducing fuel consumption.

The Hydra-Kool includes the following items:

- *Oil cooler with hydraulic or electric driven fan*
- *High flow integral 10 micron filter*
- *4 or 8 gallon reservoir capacity*
- *Sight-temperature gauge*
- *(2) 1-1/4" suction strainers w/by-pass*
- *10 micron filler-breather*
- *Filter element condition indicator*
- *1" I.D. line size*
- *Half the dry weight of any other brand!*

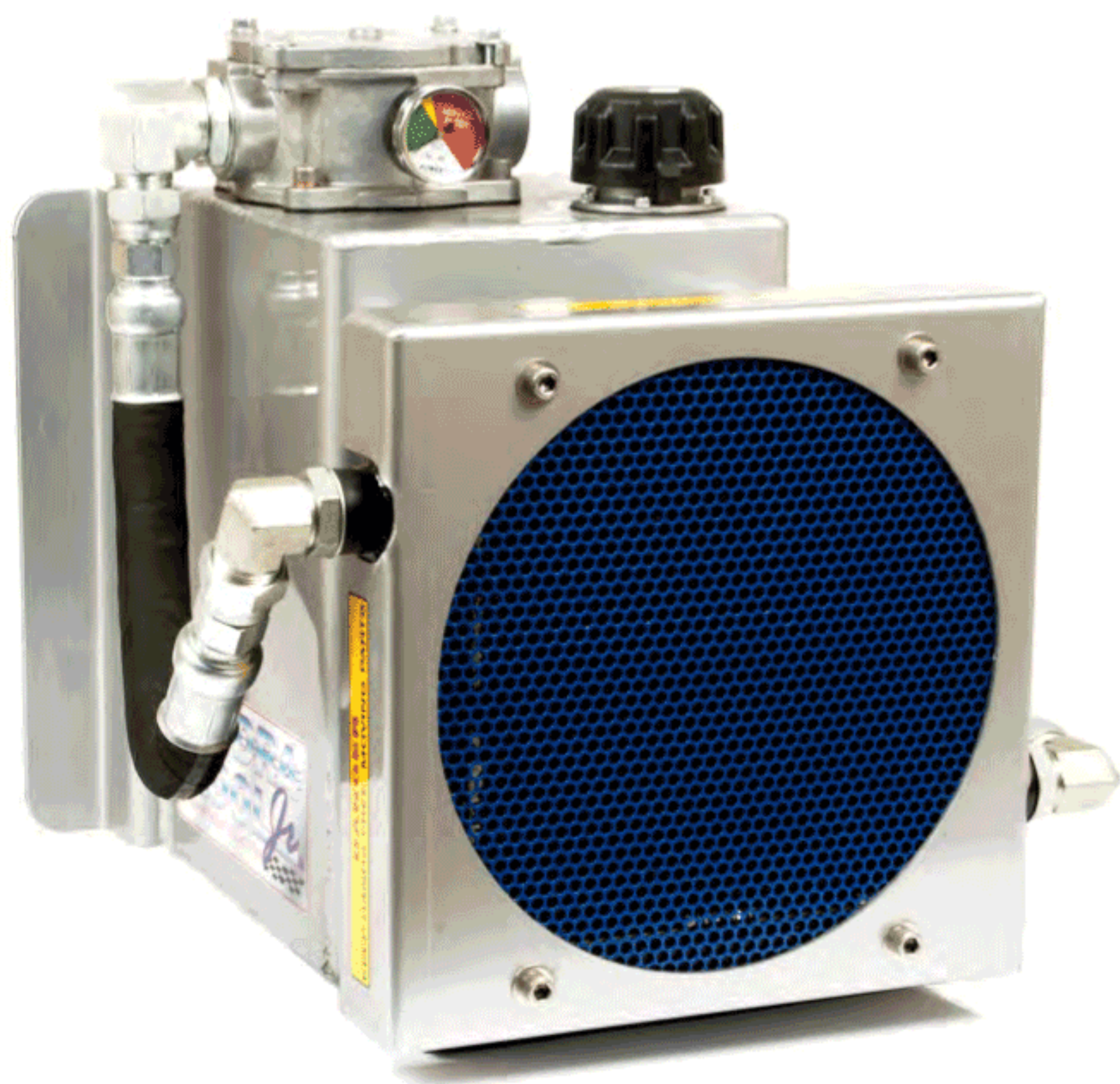

HK4-20, 4 Gallon Reservoir



HK8-40, 8 Gallon Reservoir



## PERFORMANCE CURVES

The **Inlet Temperature Difference** is the difference between the inlet oil temperature and the inlet air temperature in °F. The Smaller this difference is, the less ability the heat exchanger has to cool the oil.

- 10 gpm
- 20 gpm
- 30 gpm
- 40 gpm

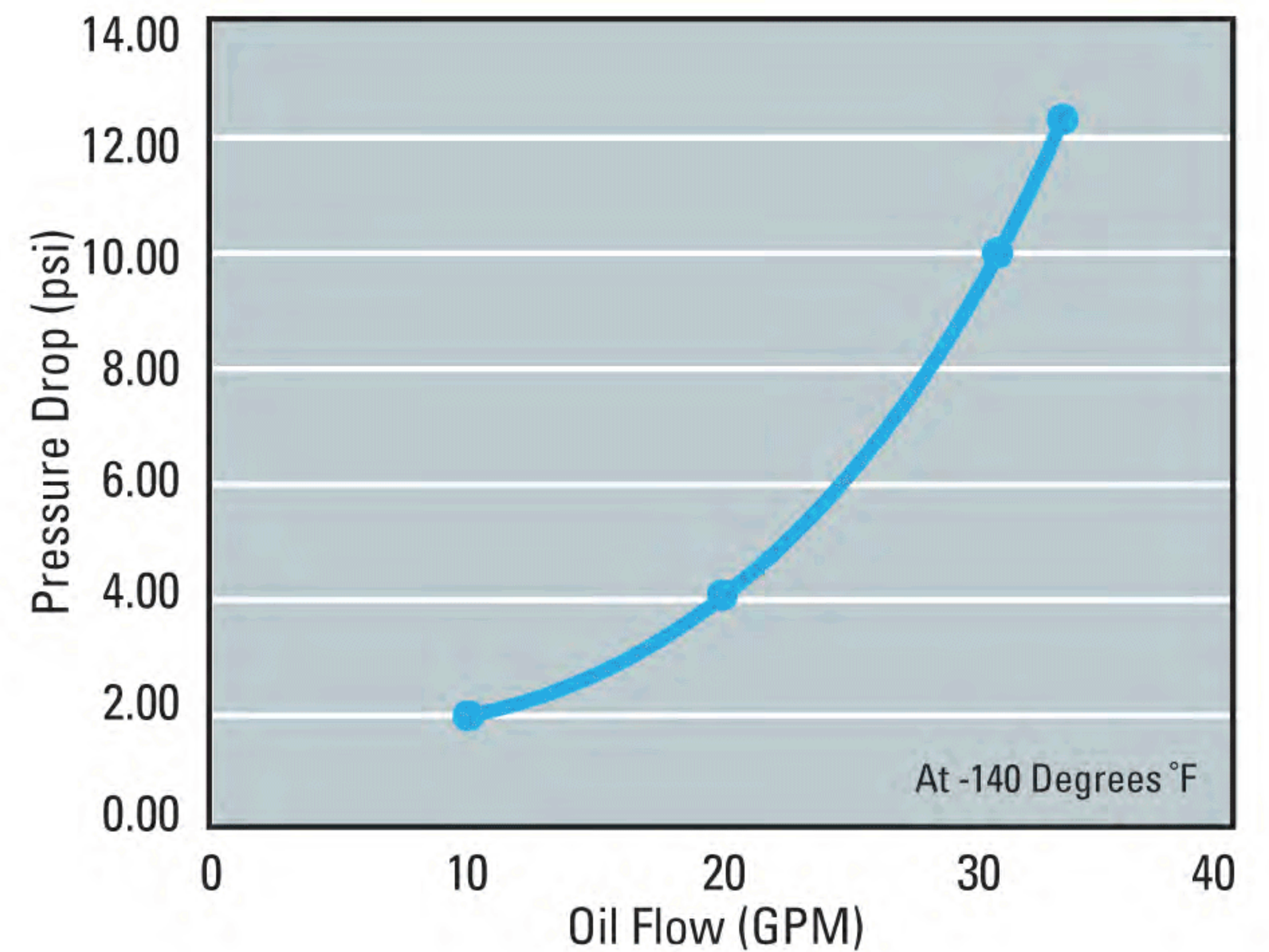
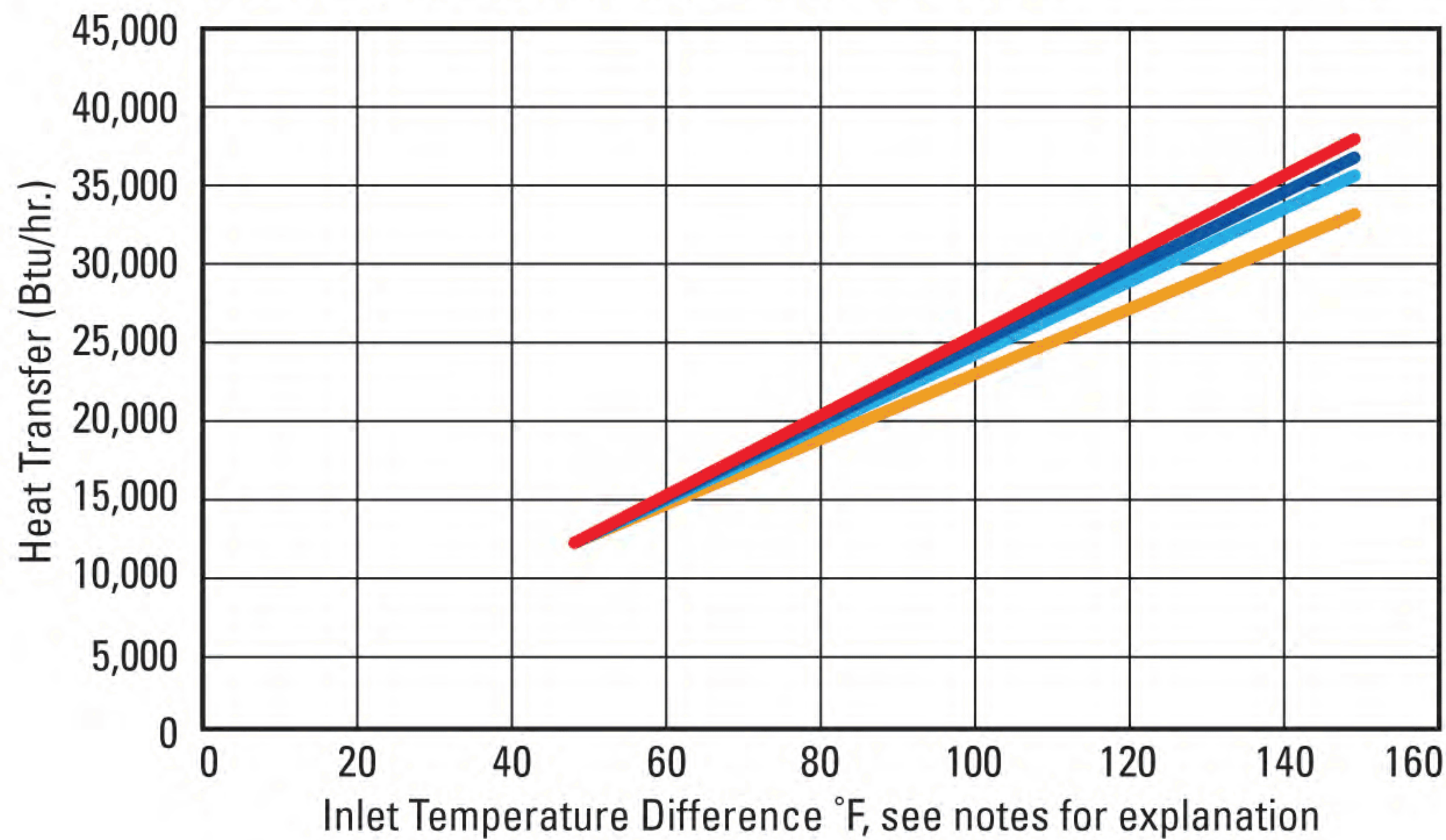

## PACKAGE DIMENSIONS

### Model Numbers

- |               |                    |                     |
|---------------|--------------------|---------------------|
| <b>HK4-20</b> | 4 Gallon Reservoir | 12VDC Fa            |
| <b>HK8-40</b> | 8 Gallon Reservoir | Hydraulic Fan Motor |

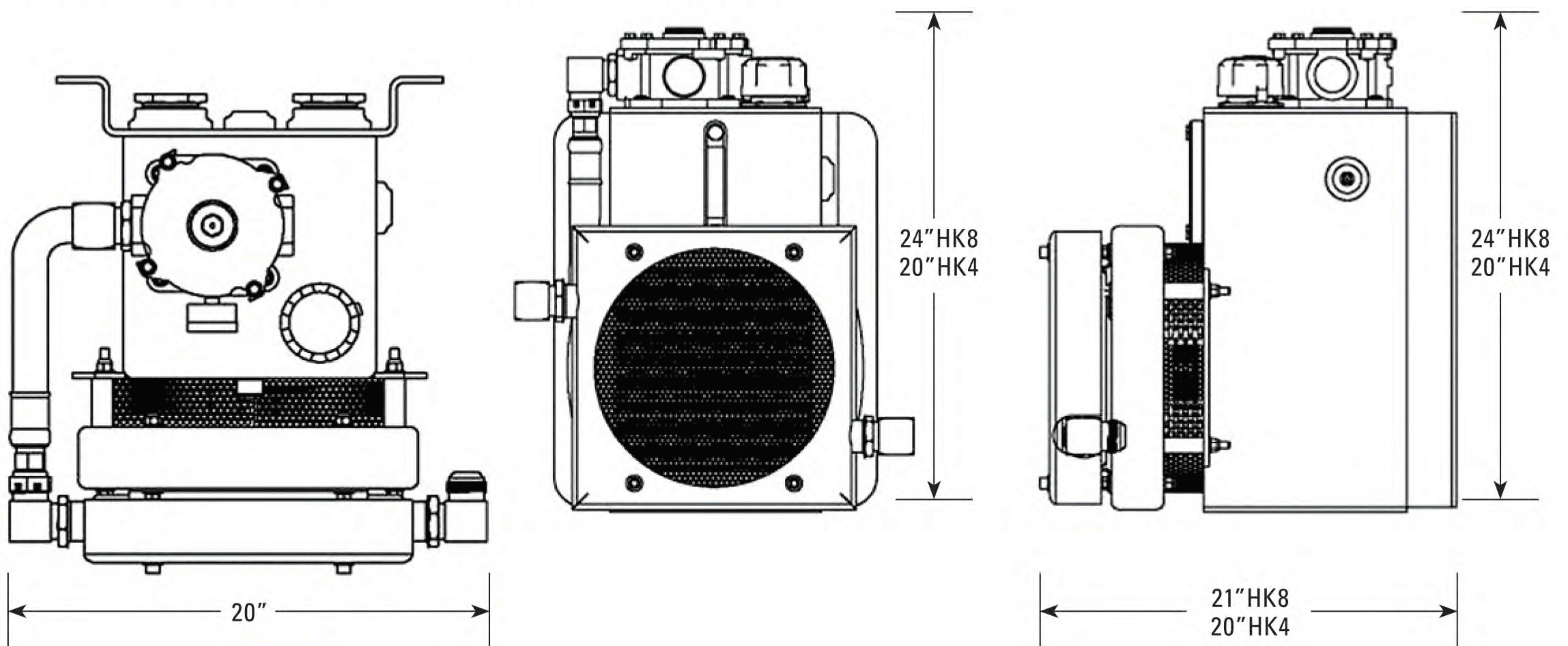

**Truck Center of Fort Worth, Inc.**  
**2901 North Freeway, Fort Worth, TX 76106**  
**800-709-3184 www.FortWorthTruck.com**